



Applications

- Aircraft avionics and equipment
- Naval electronics
- Sensitive electronic applications that require medical or NBC wash down
- Helicopter electronics

Load Range

- 1902 = 7 load ratings from 2.0-40 lbs. per mount

Attributes

- Fail safe design
- Friction damped stainless spring
- Axial to radial stiffness ratio 4:1
- Rugged construction

Specifications

- Natural Frequency— 7-10 Hertz
- Transmissibility at resonance— 2.5:1 max.
- Resilient Element—Friction damped stainless steel spring
- Standard materials—Clear anodized 6061-T6 aluminum
- Isolator weight — 1902 = .23 lbs.

Environmental Data

- Operating temperature ranges of -67°F to +250°F (-55°C to +120°C)
- Meets the requirements of MIL-C-172C

Specifications subject to change without notice. Check with factory for latest revisions. The Federal Trade Commission considers no existing test methods or standards regarding flammability as accurate indicators of the performance of cellular plastic materials under actual fire conditions. Results of existing test methods, such as UL-94, MVSS-302, SAE J-369, and FAR 25.853 are intended only as measurements of the performance of such materials under specific controlled test conditions. Any flammability ratings shown are not intended to reflect hazards presented by these materials under actual fire conditions. The information contained herein is based on laboratory test data developed for PTI and is believed to be reliable, but its accuracy or completeness is not guaranteed. The buyer must test any product to determine the suitability for his specific application before use. PTI DISCLAIMS ANY RESPONSIBILITY FOR: 1) WARRANTIES OF FITNESS AND PURPOSE, 2) VERBAL RECOMMENDATIONS, 3) CONSEQUENTIAL DAMAGES FROM USE AND 4) VIOLATION OF ANY PATENTS OF TRADEMARKS HELD BY OTHERS.



Polymer Technologies Inc.

Engineering Sound Solutions™

Elastomeric Solutions Division

Technical Data Sheet
Materials Specifications For:

Friction Style Mount Series: 1902

Part #	Static Load Range (lbs.)	Dimension "H"		
		Minimum Compressed	Approx. Under Min. Load	Maximum Extended
1902-AA-04	2.0-4.5	.98	1.41	1.54
1902-AA-06	3.0-6.0	.98	1.41	1.54
1902-AA-10	4.5-10.0	.98	1.41	1.54
1902-AA-12	6.25-12.5	.98	1.41	1.54
1902-AA-16	9.0-16.0	.98	1.41	1.54
1902-AA-20	10.0-20.0	.98	1.41	1.54
1902-AA-40	20.0-40.0	.98	1.41	1.54
1902-BA-04	2.0-4.5	1.14	1.57	1.70
1902-BA-06	3.0-6.0	1.14	1.57	1.70
1902-BA-10	4.5-10.0	1.14	1.57	1.70
1902-BA-12	6.25-12.5	1.14	1.57	1.70
1902-BA-16	9.0-16.0	1.14	1.57	1.70
1902-BA-20	10.0-20.0	1.14	1.57	1.70
1902-BA-40	20.0-40.0	1.14	1.57	1.70
1902-BAM-04	2.0-4.5	1.14	1.57	1.70
1902-BAM-06	3.0-6.0	1.14	1.57	1.70
1902-BAM-10	4.5-10.0	1.14	1.57	1.70
1902-BAM-12	6.25-12.5	1.14	1.57	1.70
1902-BAM-16	9.0-16.0	1.14	1.57	1.70
1902-BAM-20	10.0-20.0	1.14	1.57	1.70
1902-BAM-40	20.0-40.0	1.14	1.57	1.70

Specifications subject to change without notice. Check with factory for latest revisions. The Federal Trade Commission considers no existing test methods or standards regarding flammability as accurate indicators of the performance of cellular plastic materials under actual fire conditions. Results of existing test methods, such as UL-94, MVSS-302, SAE J-369, and FAR 25.853 are intended only as measurements of the performance of such materials under specific controlled test conditions. Any flammability ratings shown are not intended to reflect hazards presented by these materials under actual fire conditions. The information contained herein is based on laboratory test data developed for PTI and is believed to be reliable, but its accuracy or completeness is not guaranteed. The buyer must test any product to determine the suitability for his specific application before use. PTI DISCLAIMS ANY RESPONSIBILITY FOR: 1) WARRANTIES OF FITNESS AND PURPOSE, 2) VERBAL RECOMMENDATIONS, 3) CONSEQUENTIAL DAMAGES FROM USE AND 4) VIOLATION OF ANY PATENTS OF TRADEMARKS HELD BY OTHERS.

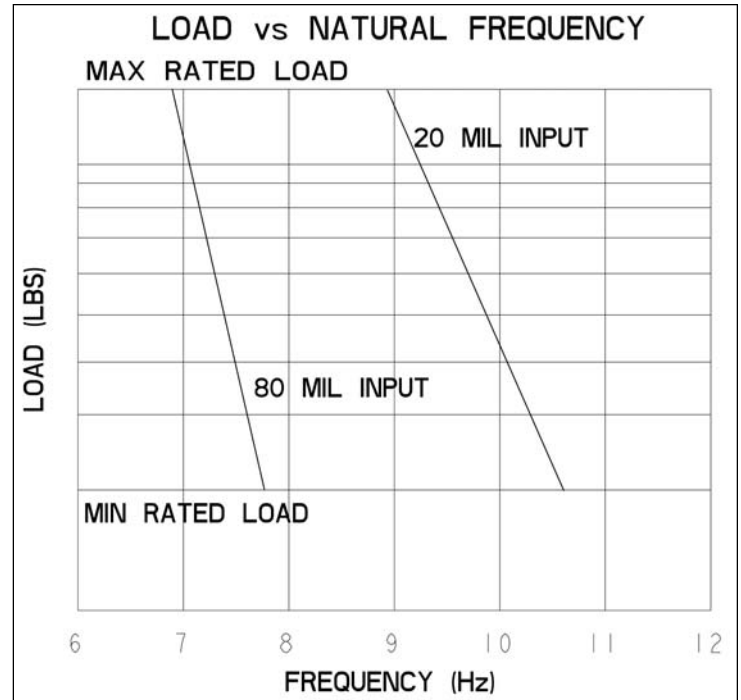
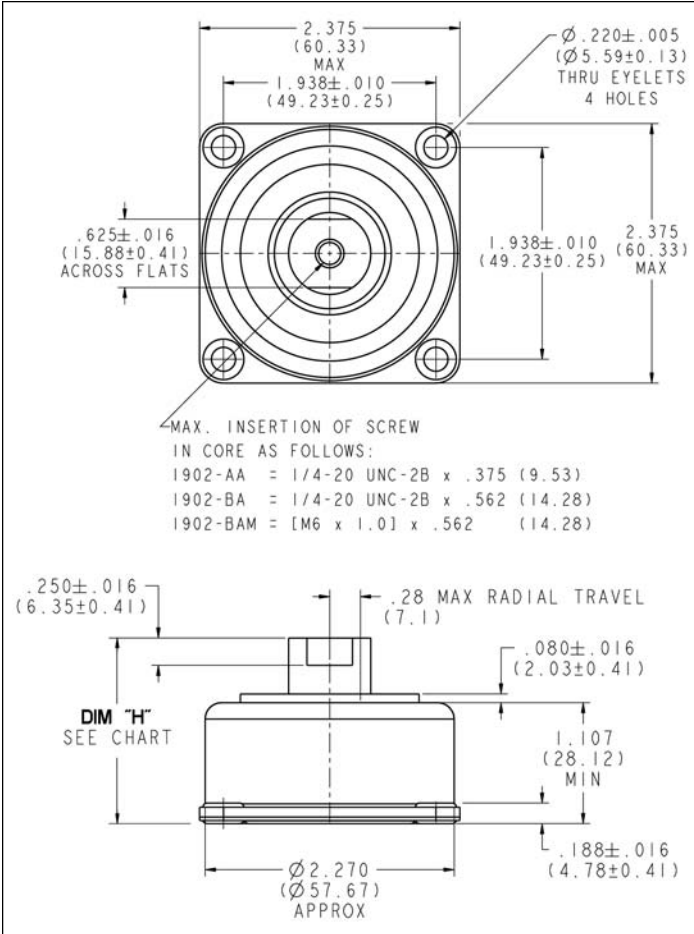

Specifications subject to change without notice. Check with factory for latest revisions. The Federal Trade Commission considers no existing test methods or standards regarding flammability as accurate indicators of the performance of cellular plastic materials under actual fire conditions. Results of existing test methods, such as UL-94, MVSS-302, SAE J-369, and FAR 25.853 are intended only as measurements of the performance of such materials under specific controlled test conditions. Any flammability ratings shown are not intended to reflect hazards presented by these materials under actual fire conditions. The information contained herein is based on laboratory test data developed for PTI and is believed to be reliable, but its accuracy or completeness is not guaranteed. The buyer must test any product to determine the suitability for his specific application before use. PTI DISCLAIMS ANY RESPONSIBILITY FOR: 1) WARRANTIES OF FITNESS AND PURPOSE, 2) VERBAL RECOMMENDATIONS, 3) CONSEQUENTIAL DAMAGES FROM USE AND 4) VIOLATION OF ANY PATENTS OR TRADEMARKS HELD BY OTHERS.